

この度は、弊社製品をお買求めいただきましてありがとうございました。
本製品は組立式になっておりますので、下記の要領で組立ててください。
パッキングケースの中には、下記の部品が入っています。

**組立説明書は組立て後も
大切に保管してください。**

この製品を第三者に貸し出すときは、この説明書も共に
貸し出し、よく読んでから使用するようご指導ください。

完成図

※本製品は組立て方によって、2通りの使い方ができます。

Aタイプ

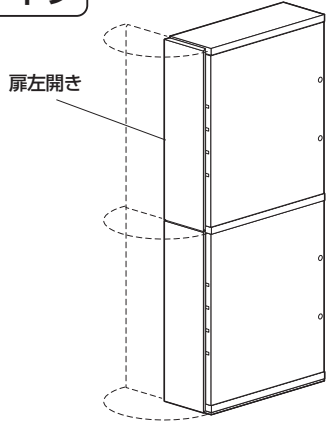

Bタイプ

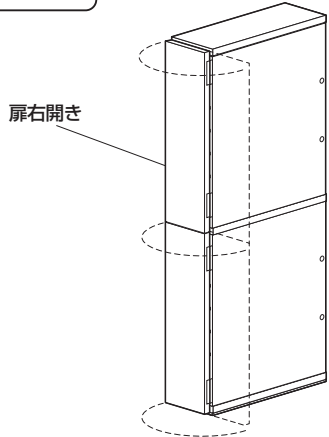

組立部品

※部品の欠品や破損があった場合は、品番(200-CB060DBRMなど)と
下記の部品番号(①~⑭)と部品名(ネジAなど)をお知らせください。

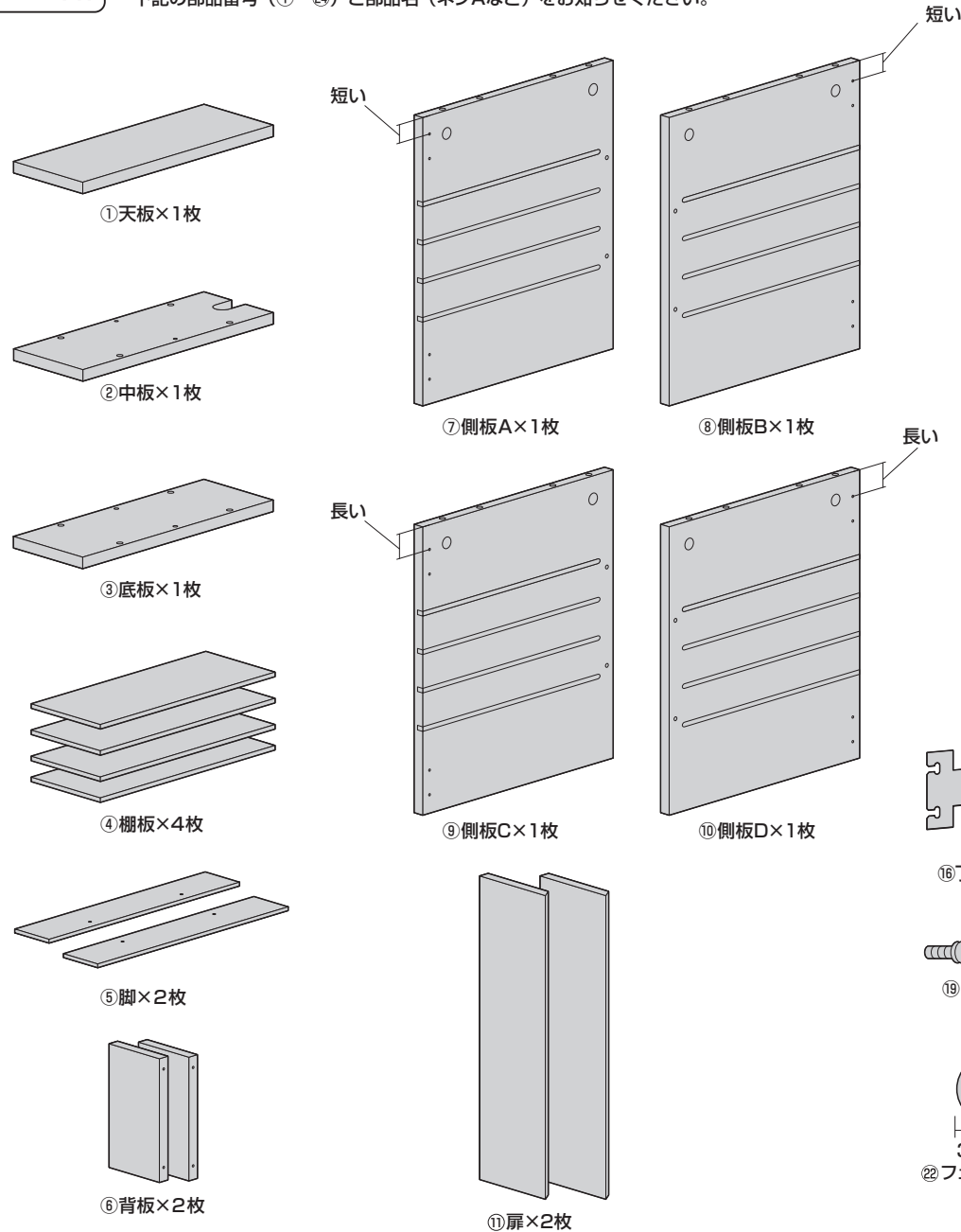

使用ボルト類

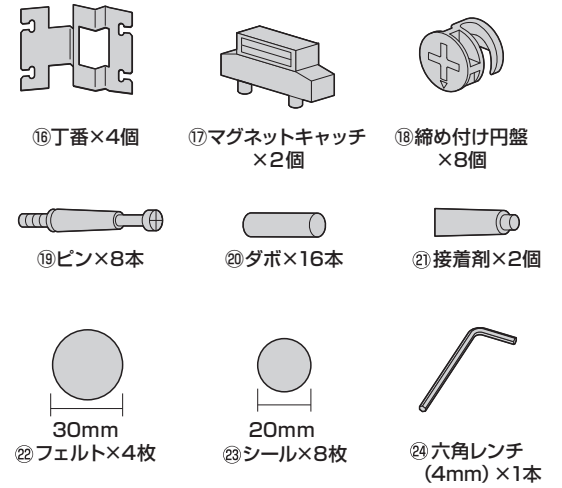
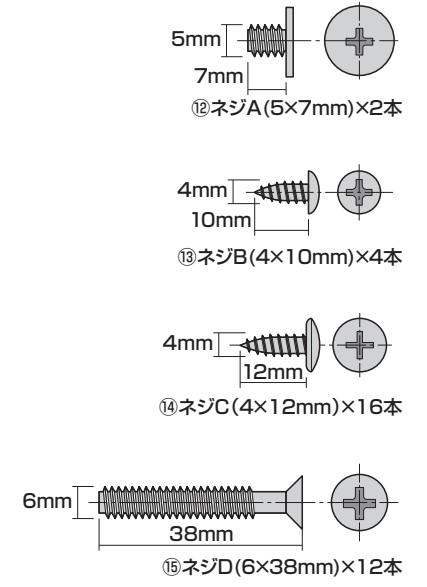

<組立てに必要な人数>

大人1人以上

<用意していただくもの>

- ・プラスドライバー
- ・手袋(ケガ等を防ぐために着用をおすすめします)

手順 A-7

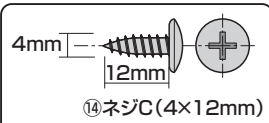
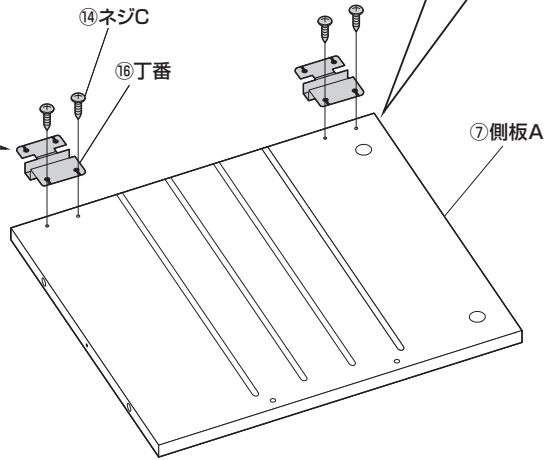
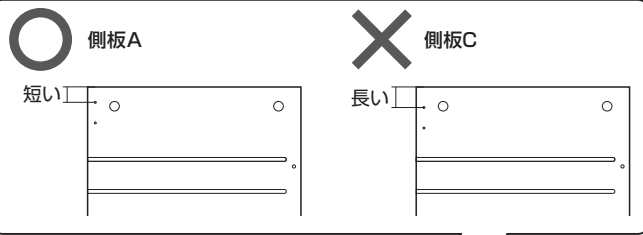
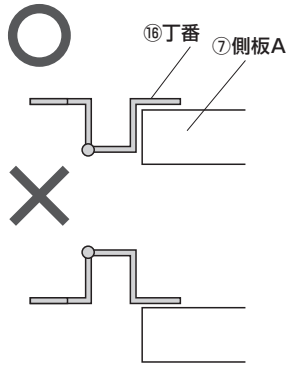

手順 A-8

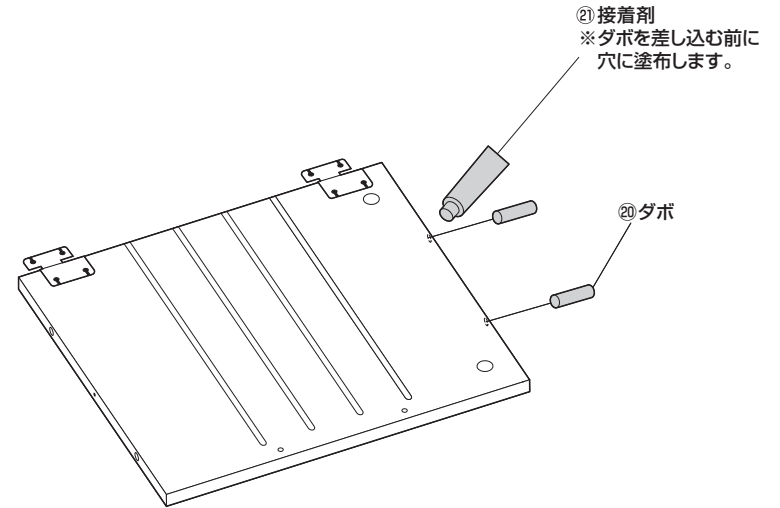

手順 A-9

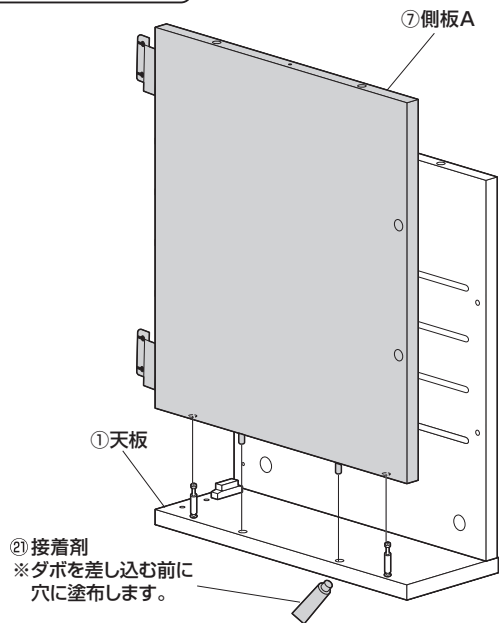

手順 A-10

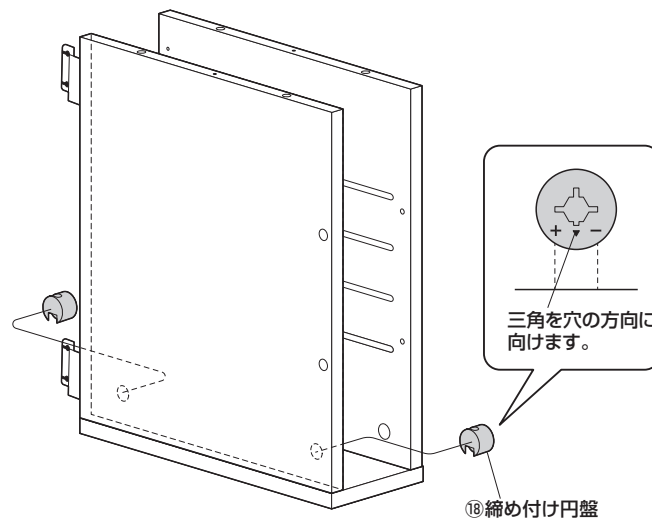

手順 A-11

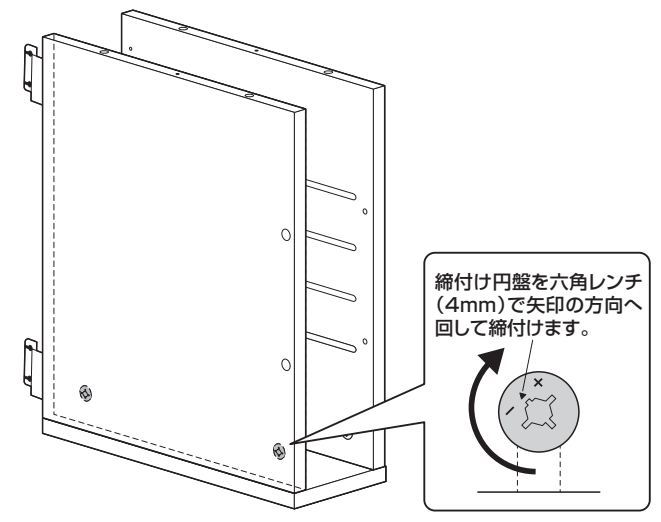

手順 A-12

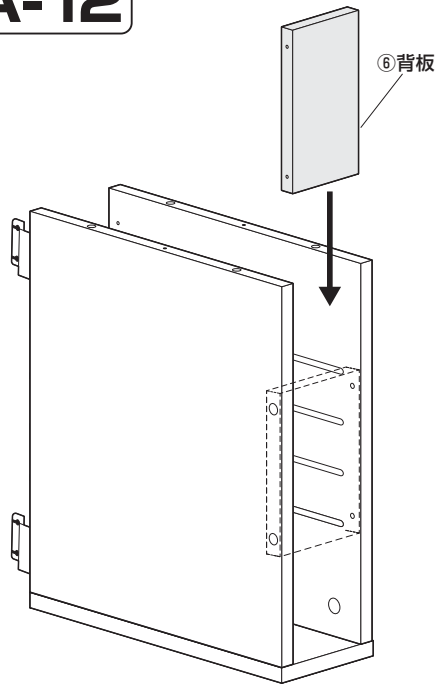

手順 A-13

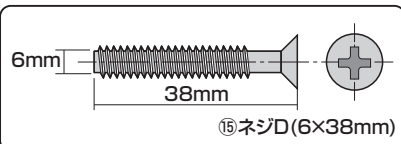
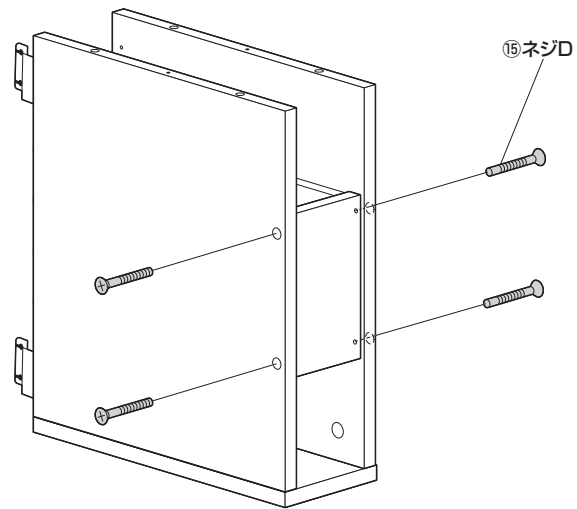

手順 A-14

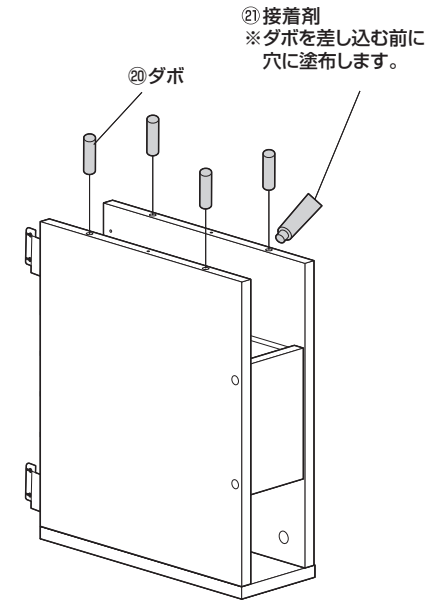

手順 A-15

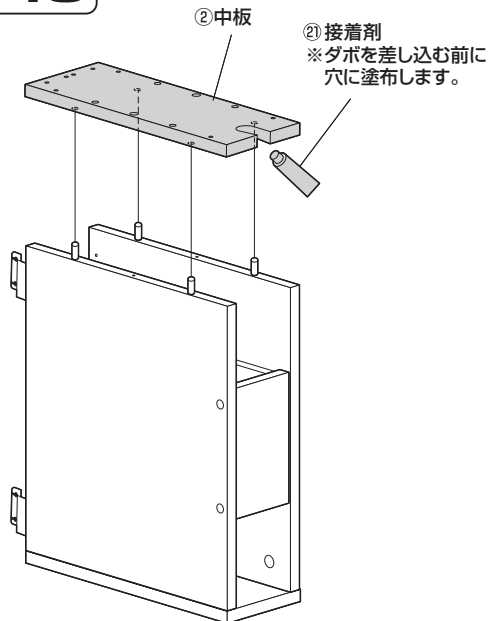

手順 A-16

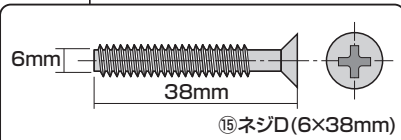
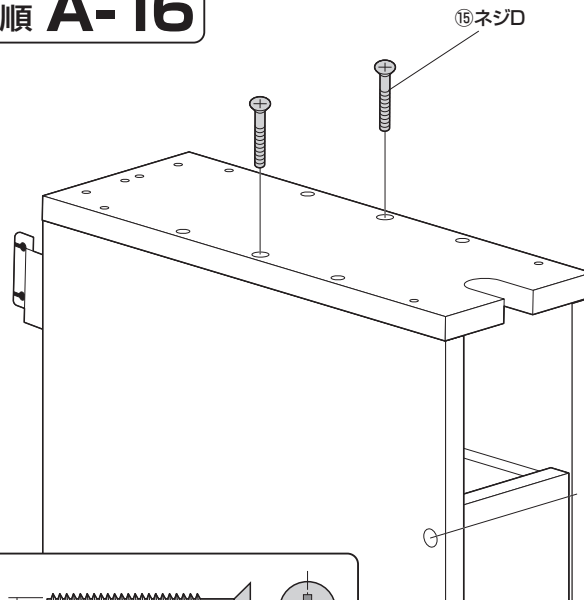

手順 A-17

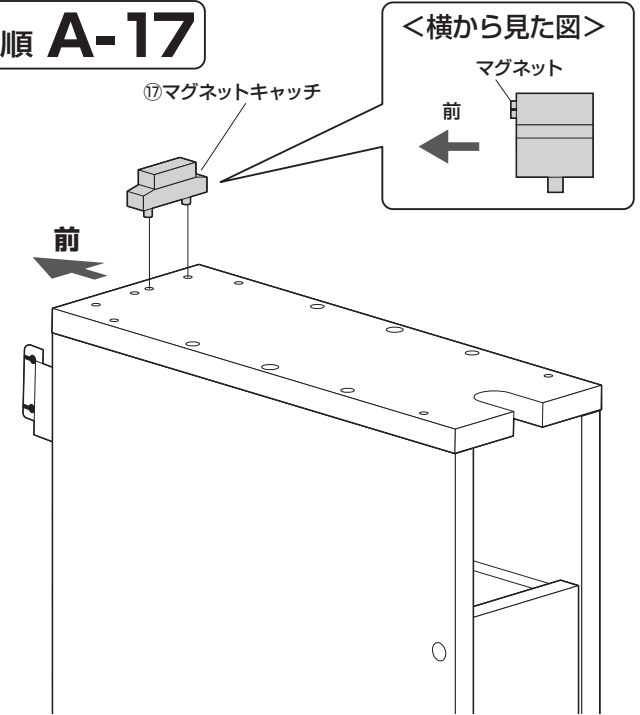

手順 A-18

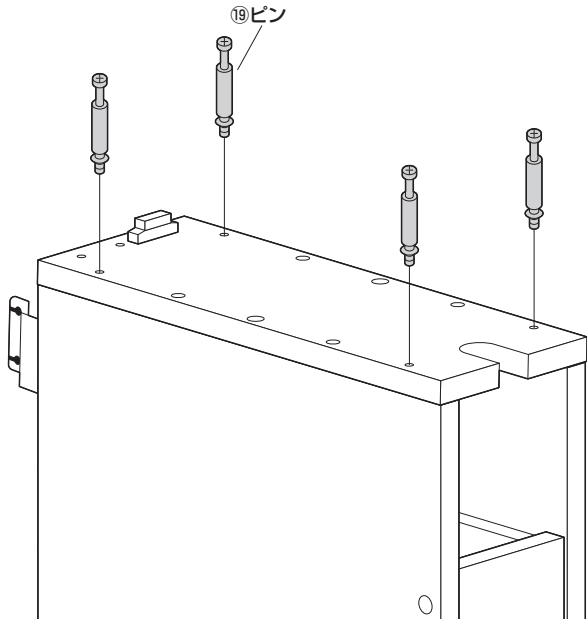

手順 A-19

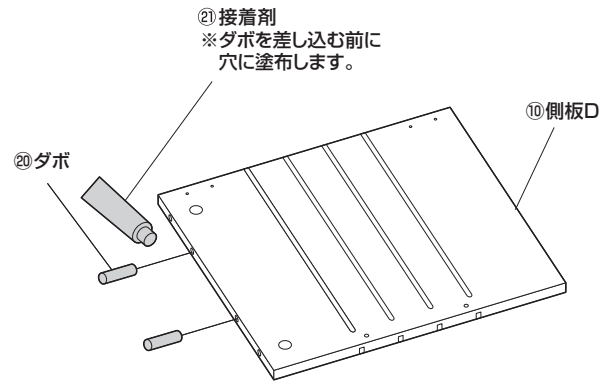

手順 A-20

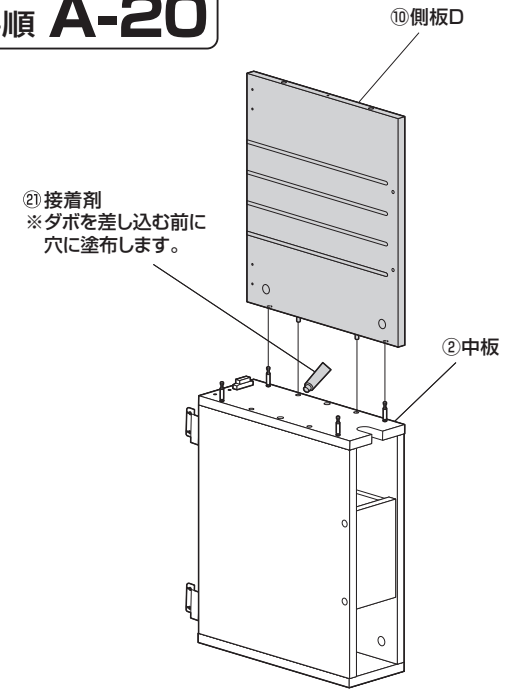

手順 A-21

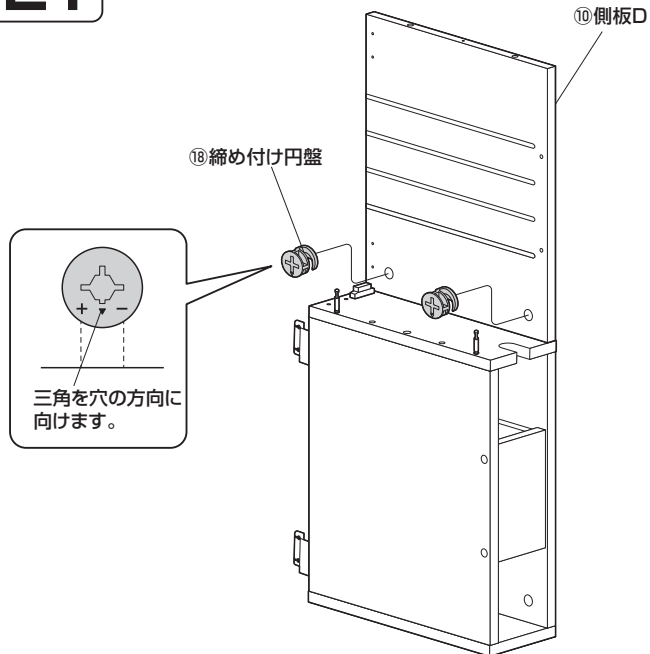

手順 A-22

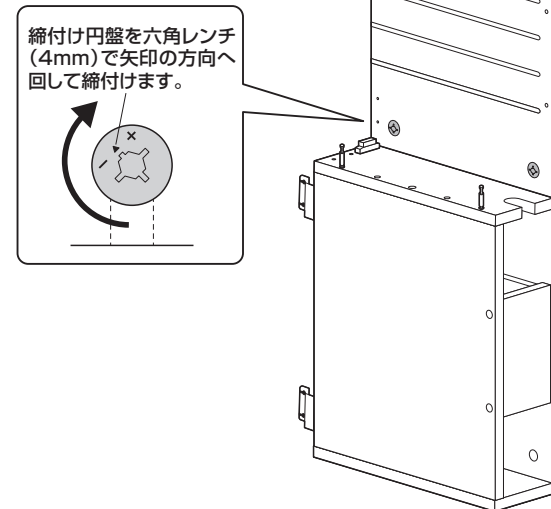

手順 A-23

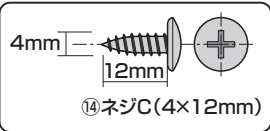
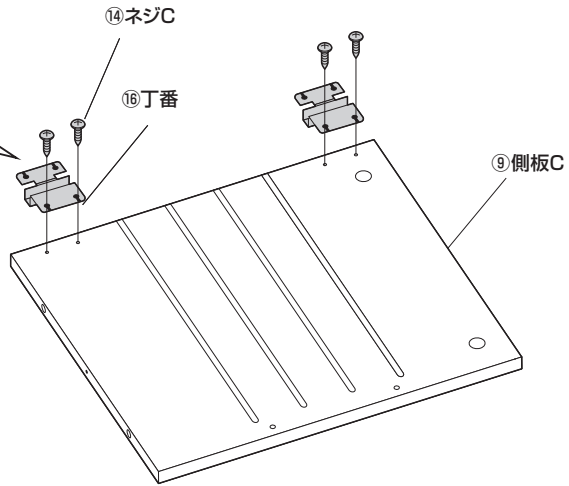
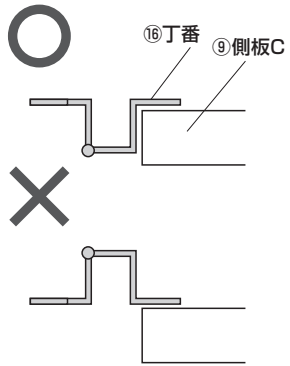

手順 A-24

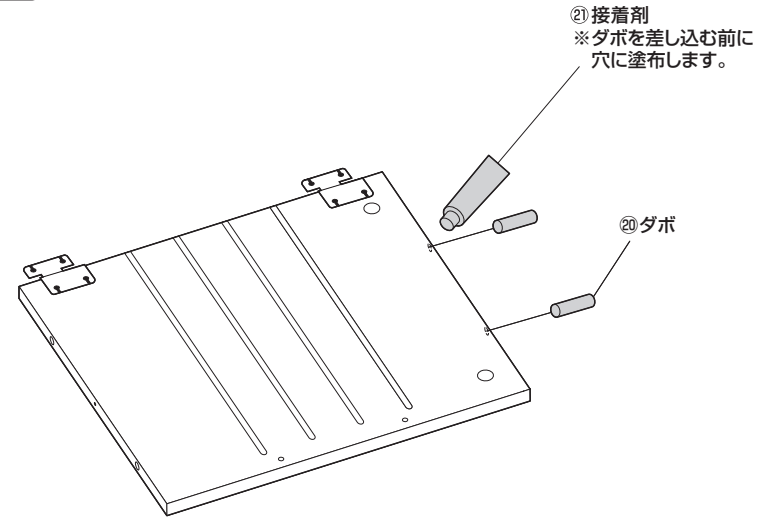

手順 A-25

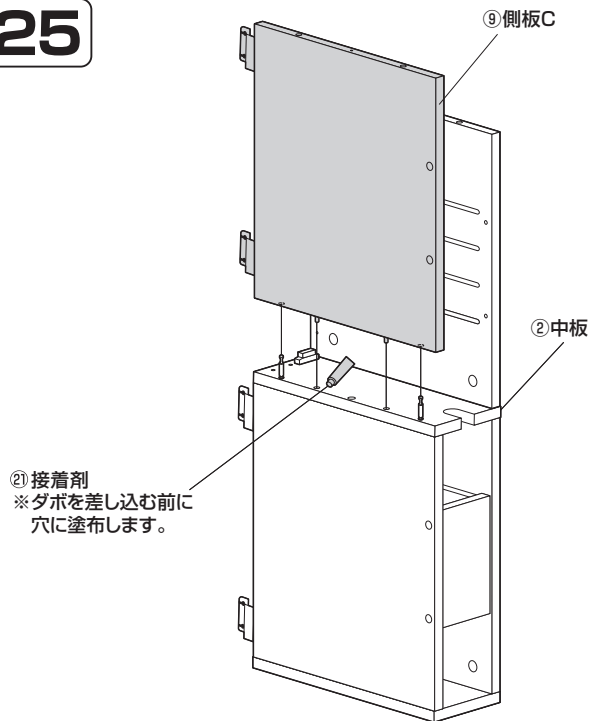

手順 A-26

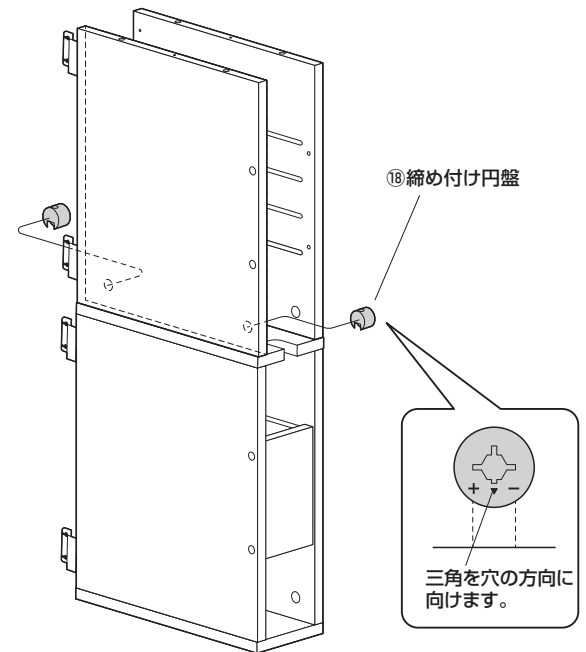

手順 A-27

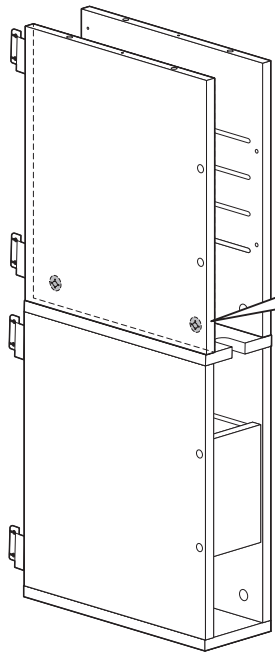

締付け円盤を六角レンチ
(4mm)で矢印の方向へ
回して締付けます。

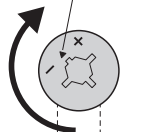

手順 A-28

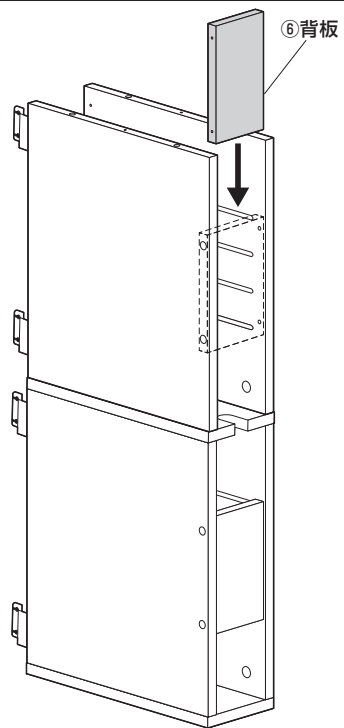

⑥背板

手順 A-29

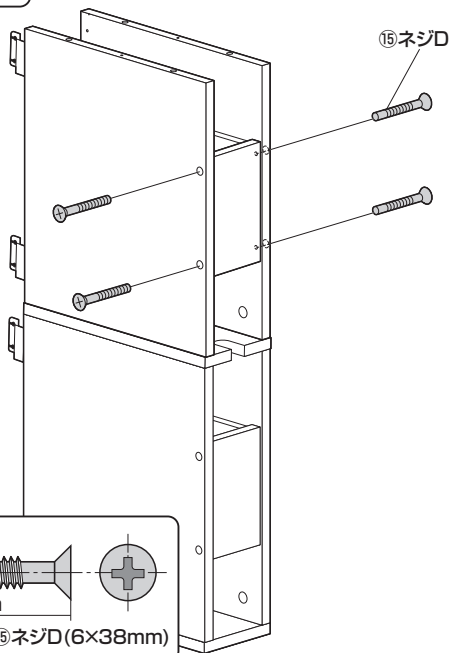

⑮ネジD

6mm
38mm

⑮ネジD(6×38mm)

手順 A-30

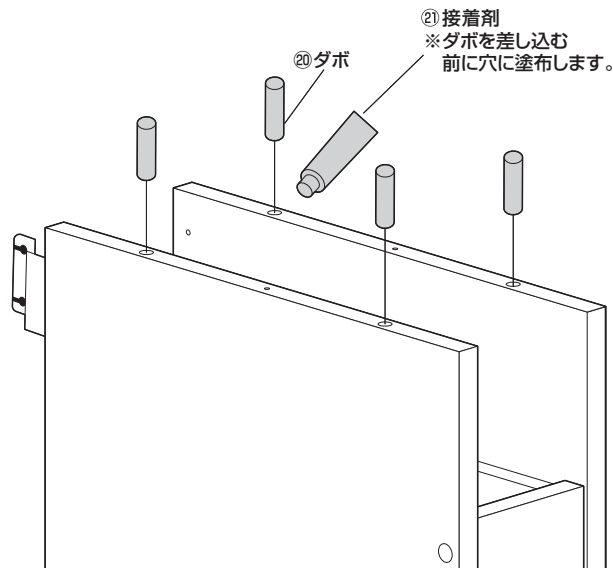

⑳接着剤
※ダボを差し込む
前に穴に塗布します。

㉑ダボ

手順 A-31

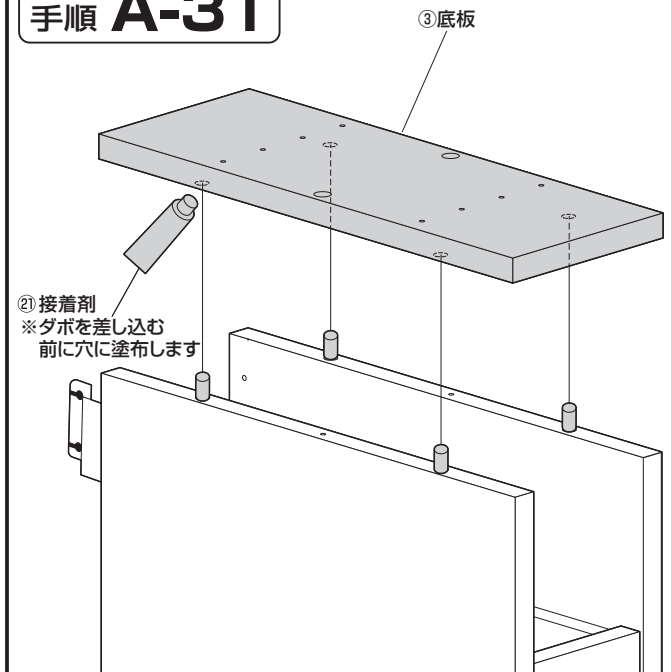

㉒底板

㉑接着剤
※ダボを差し込む
前に穴に塗布します

手順 A-32

⑮ネジD

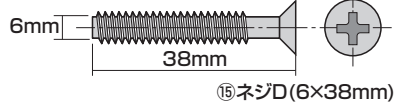
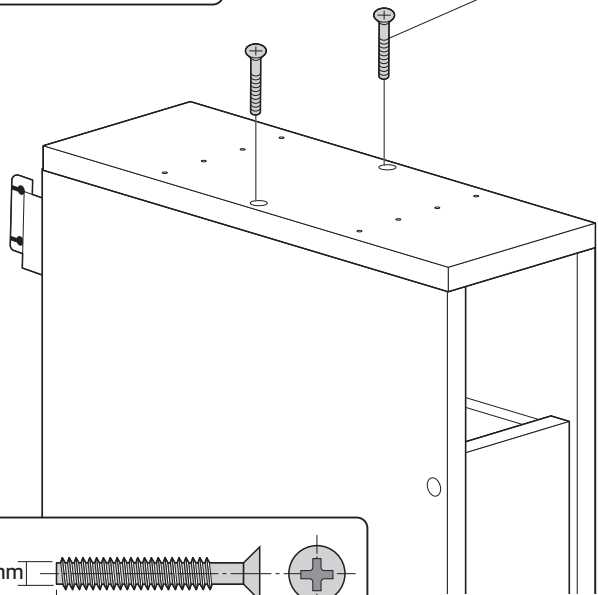

⑮ネジD(6×38mm)

手順 A-33

⑬ネジB

⑤脚

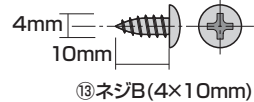
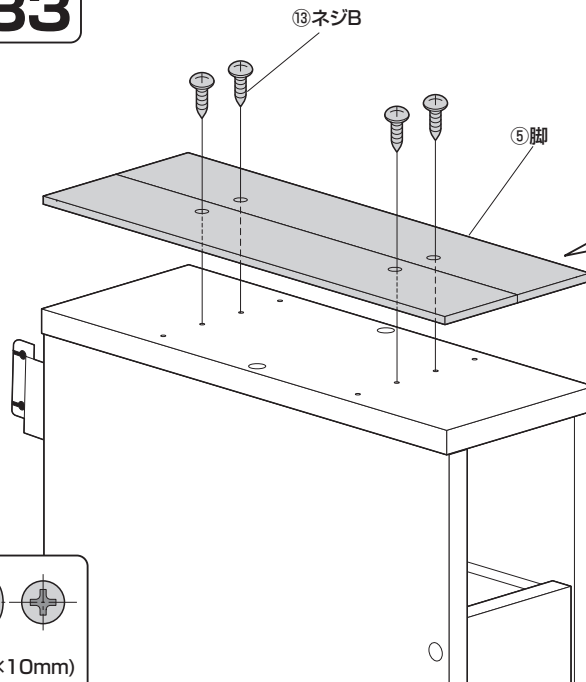

⑬ネジB(4×10mm)

※任意の位置で取付けます。

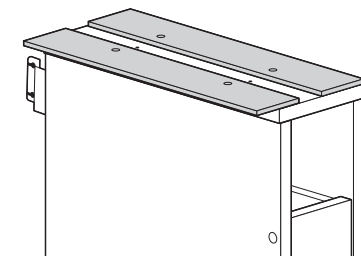
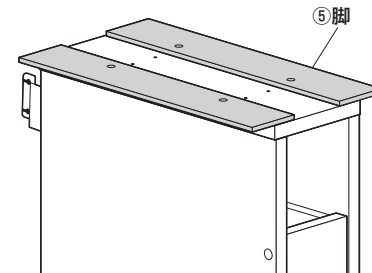

手順 A-34

⑳フェルト

※台紙からはがして
貼り付けます。

台紙

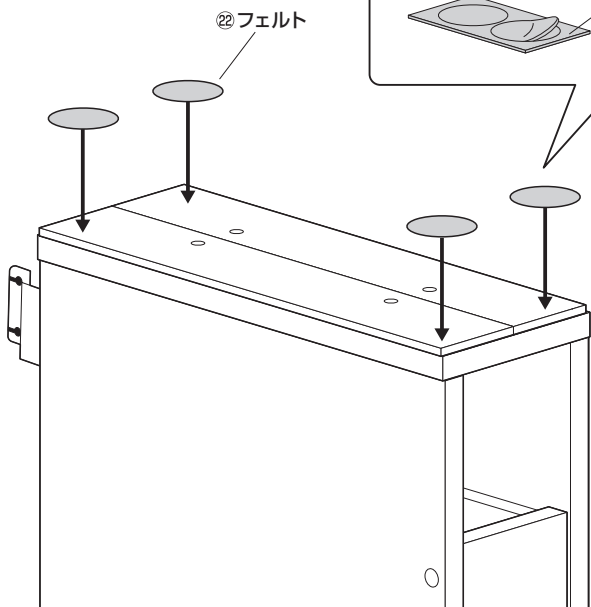
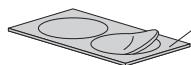

手順 A-35

横にする

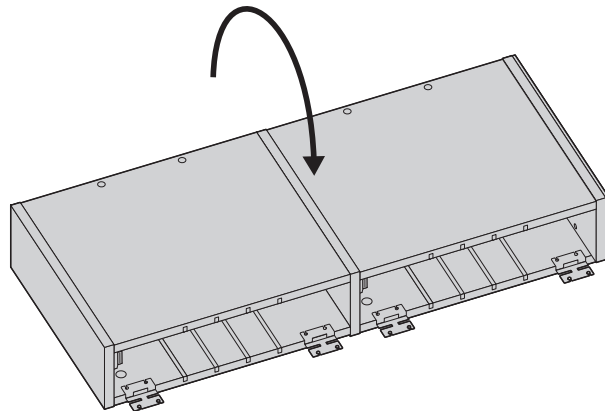

手順 A-36

⑭ネジC

⑪扉

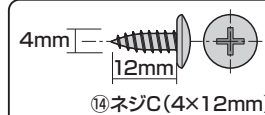
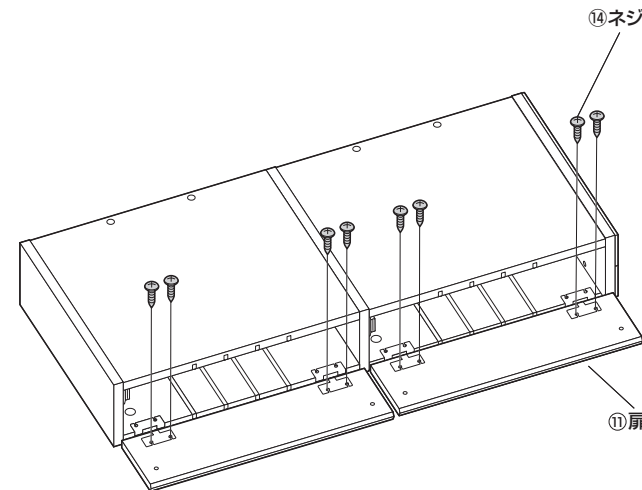

⑭ネジC(4×12mm)

手順 A-37

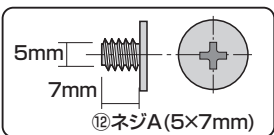
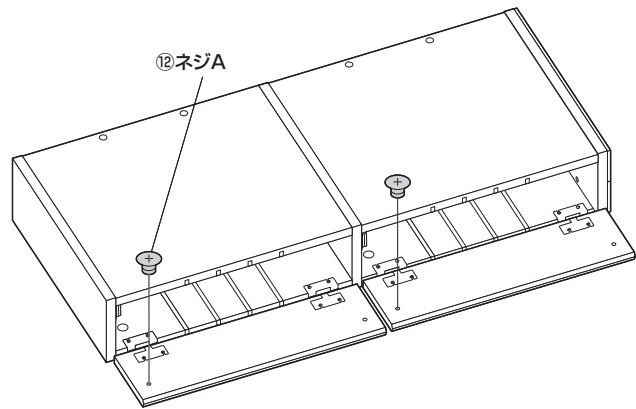

手順 A-38

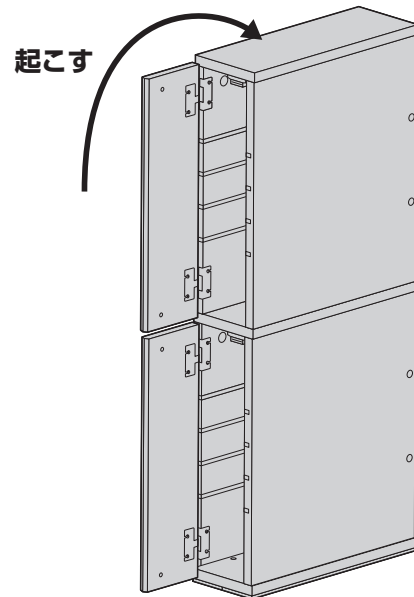

手順 A-39

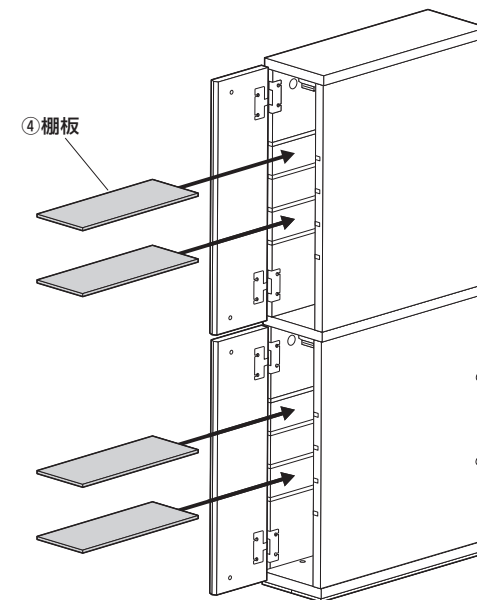

手順 A-40

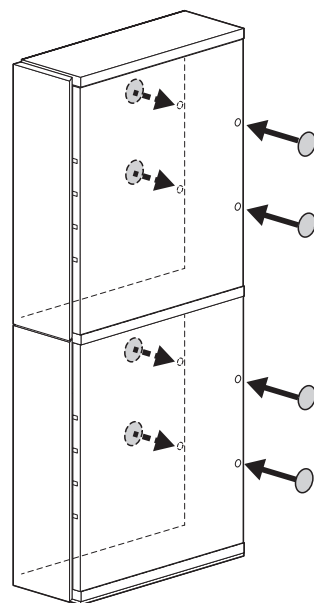

※台紙からはがして
貼り付けます。

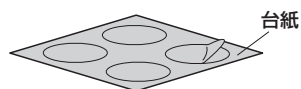

手順 B-7

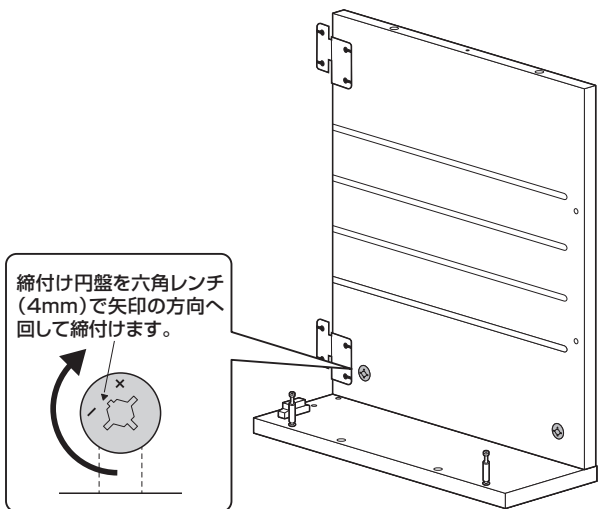

手順 B-8

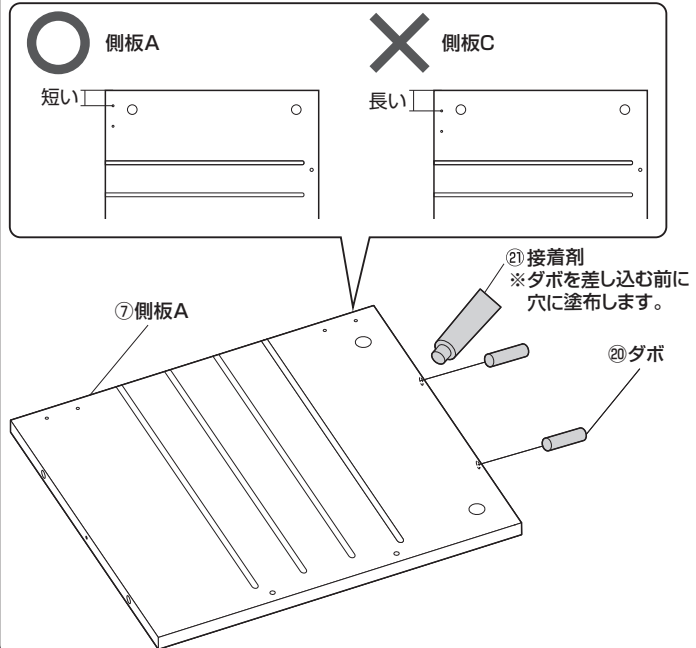

手順 B-9

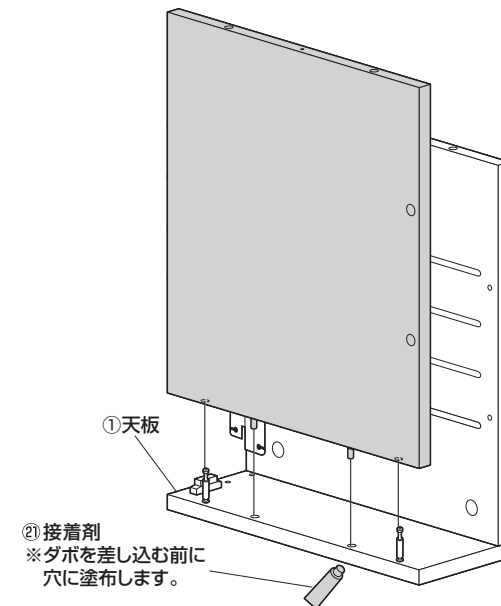

手順 B-10

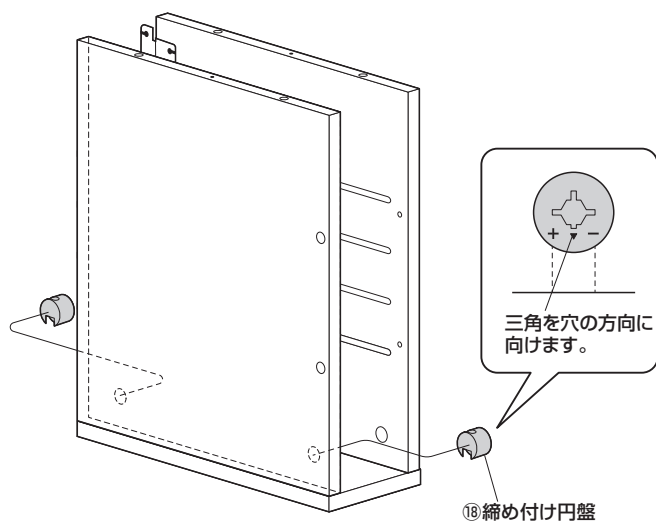

手順 B-11

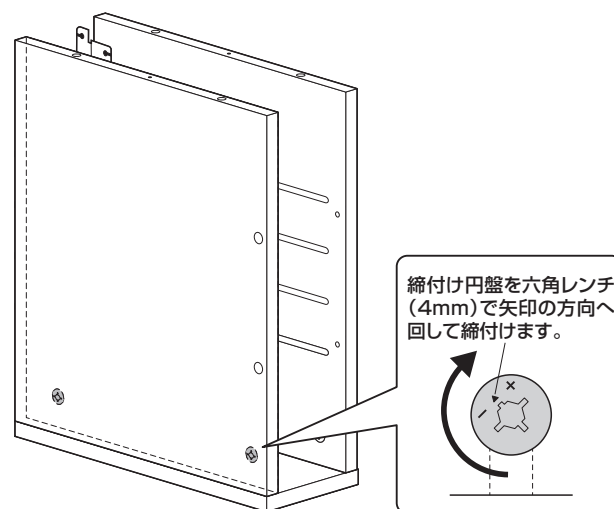

手順 B-12

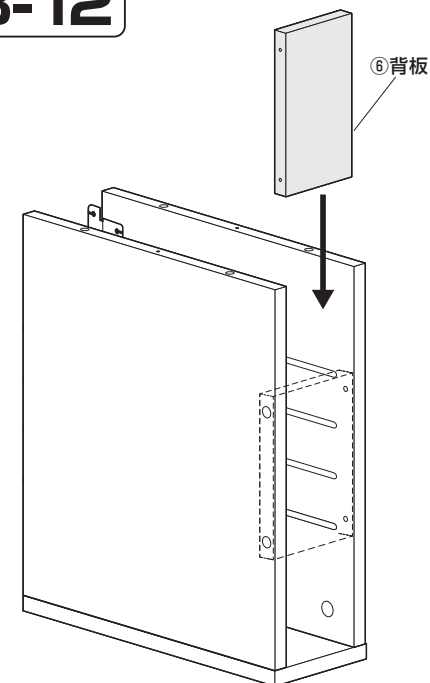

手順 B-13

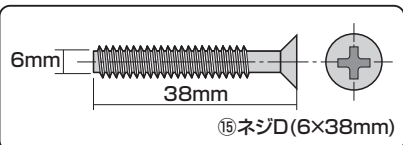
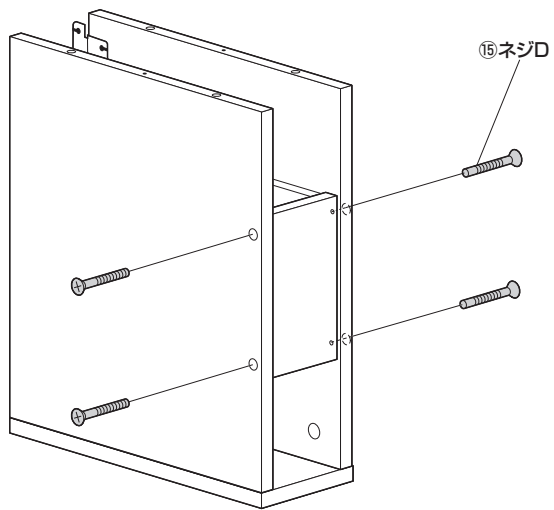

手順 B-14

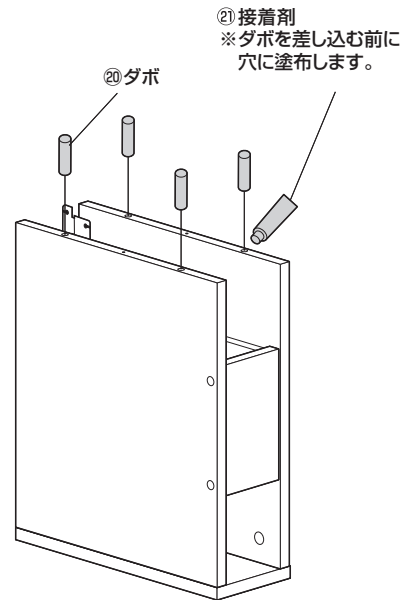

手順 B-15

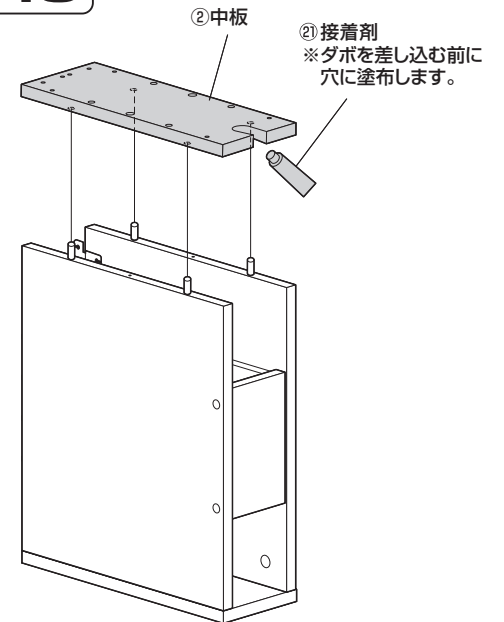

手順 B-16

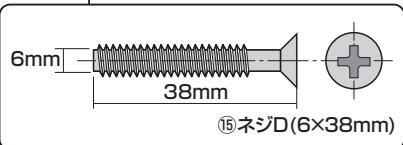
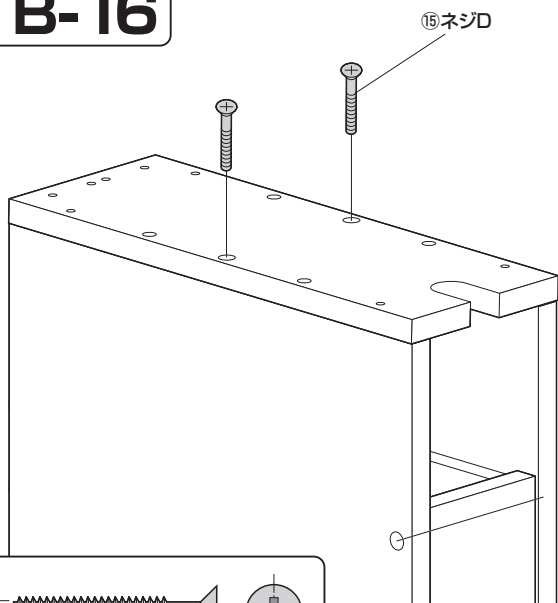

手順 B-17

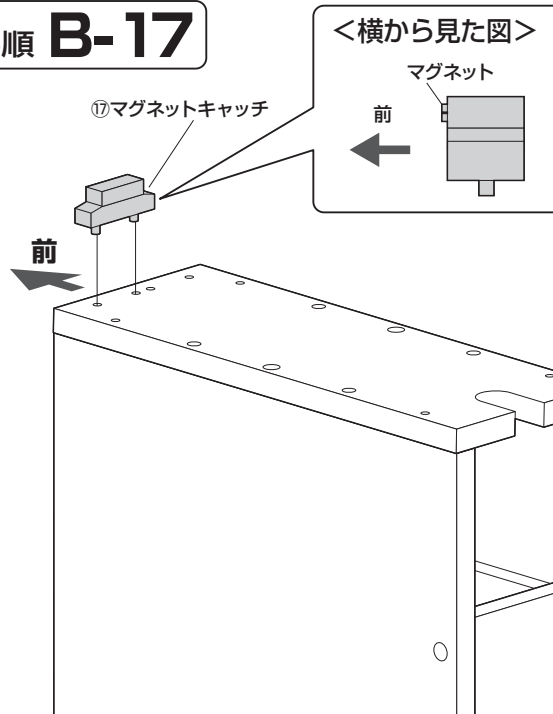

手順 B-18

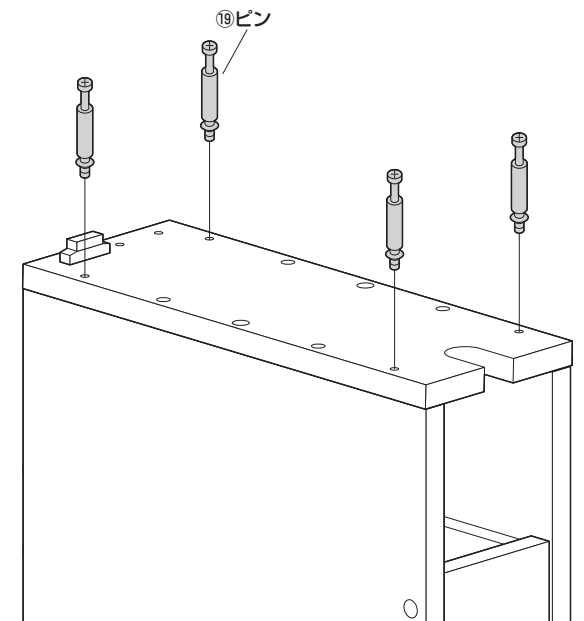

手順 B-19

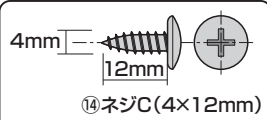
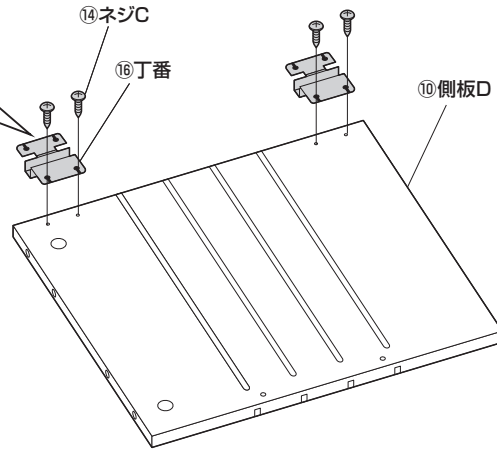
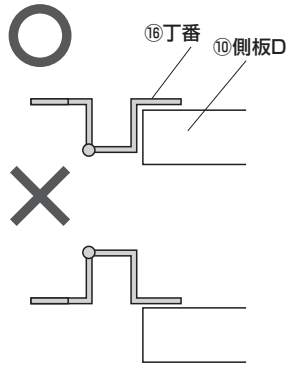

手順 B-20

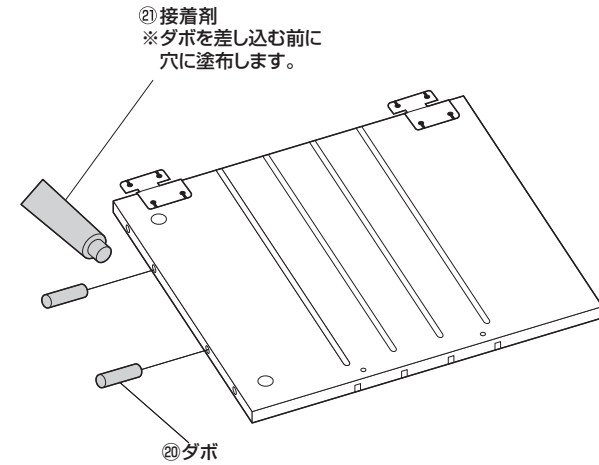

手順 B-21

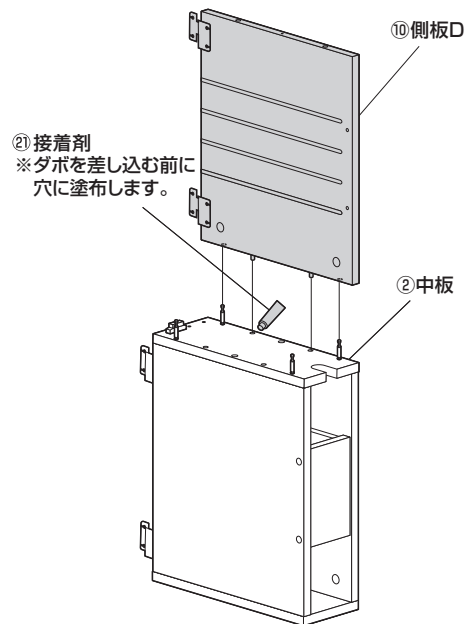

手順 B-22

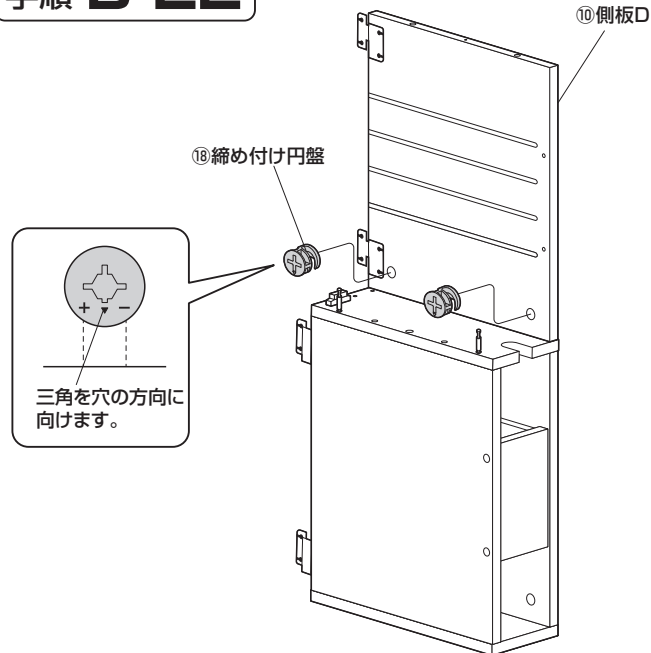

手順 B-23

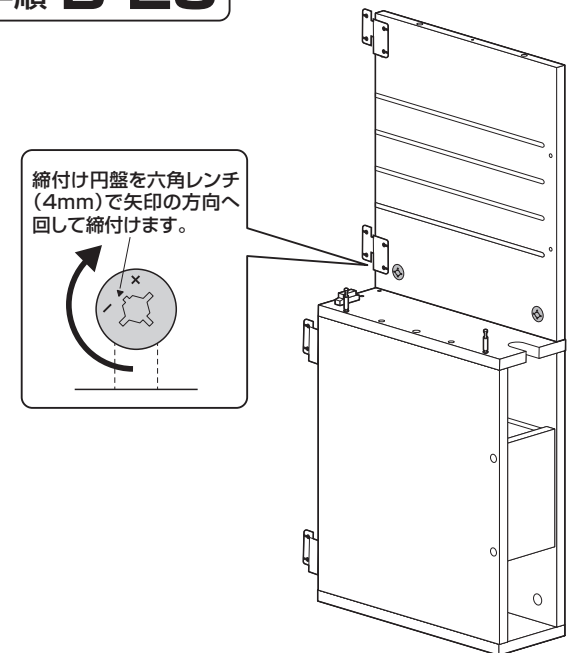

手順 B-24

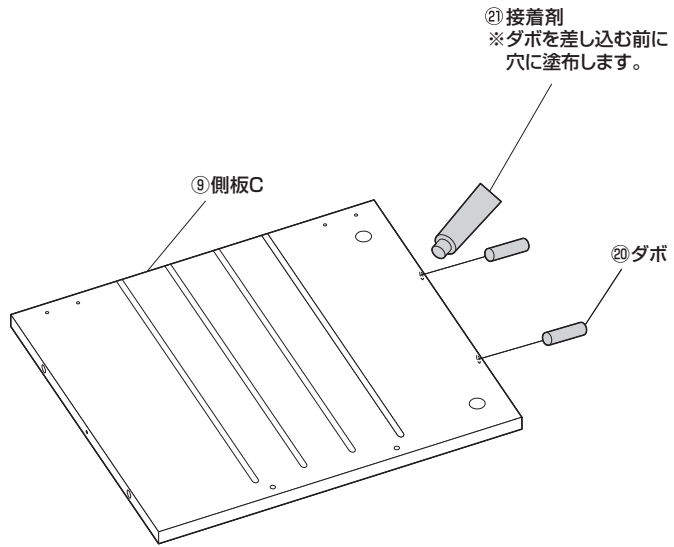

手順 B-25

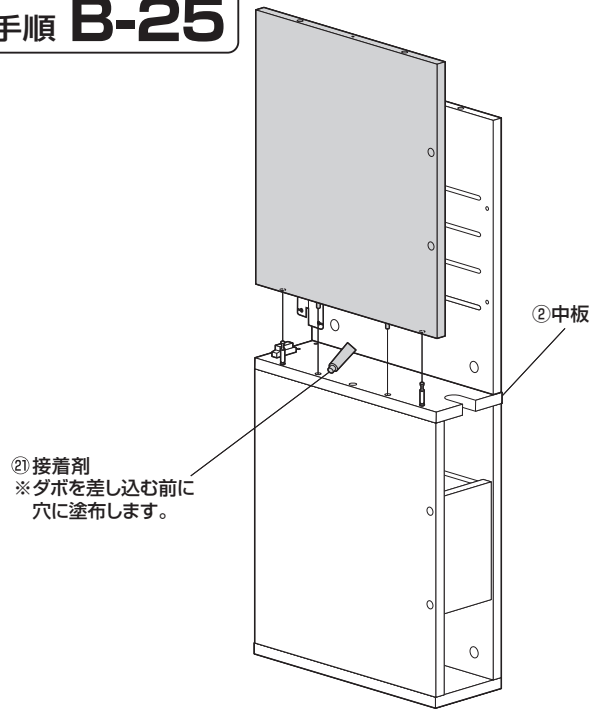

手順 B-26

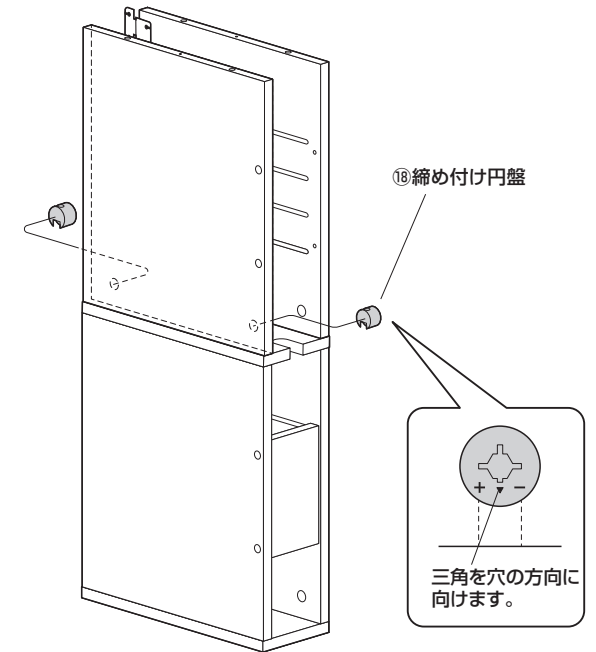

手順 B-27

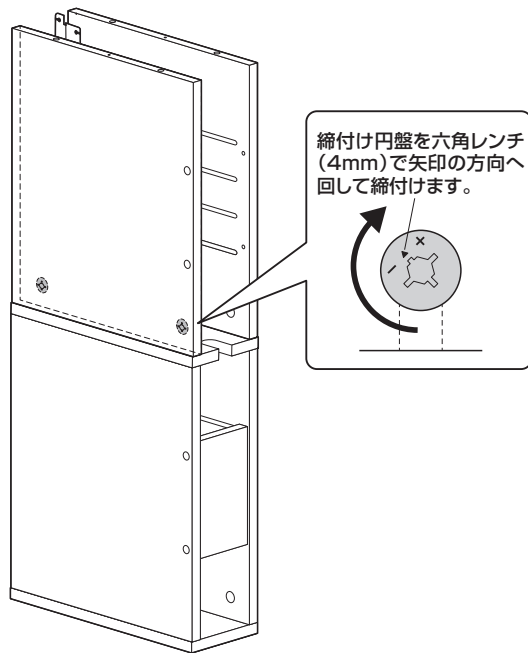

手順 B-28

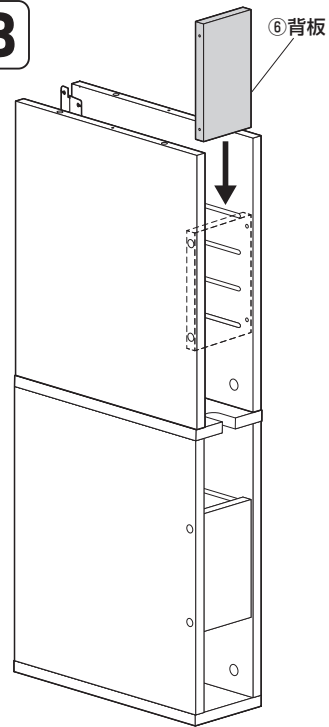

手順 B-29

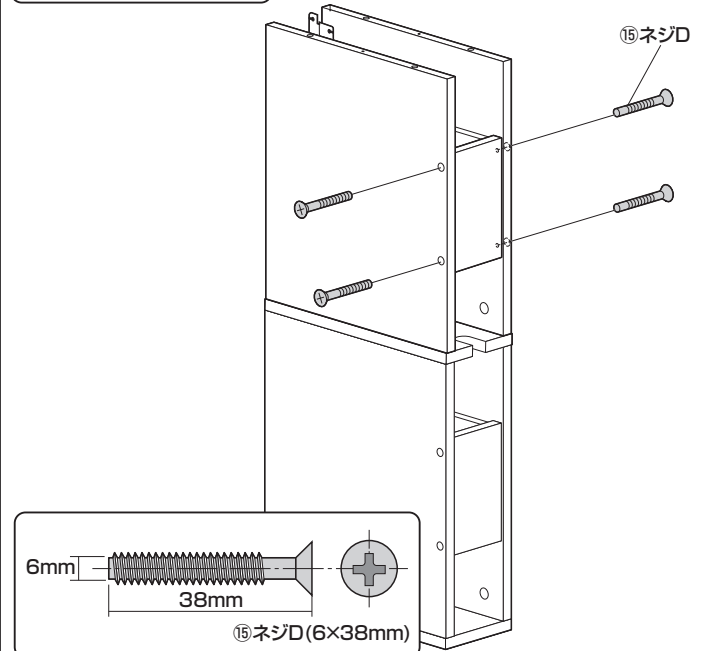

手順 B-30

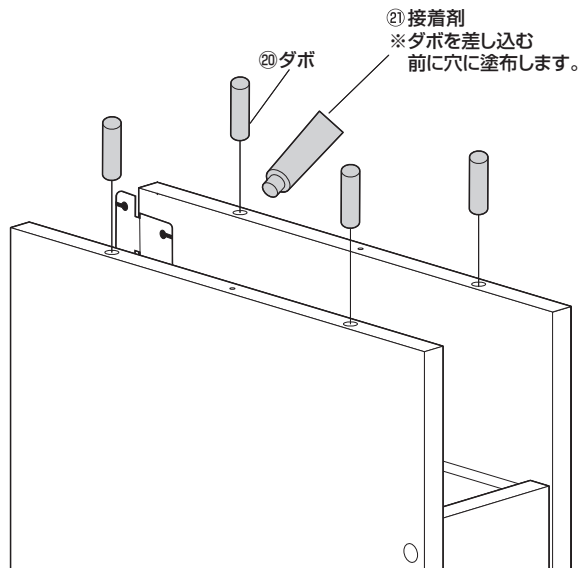

手順 B-31

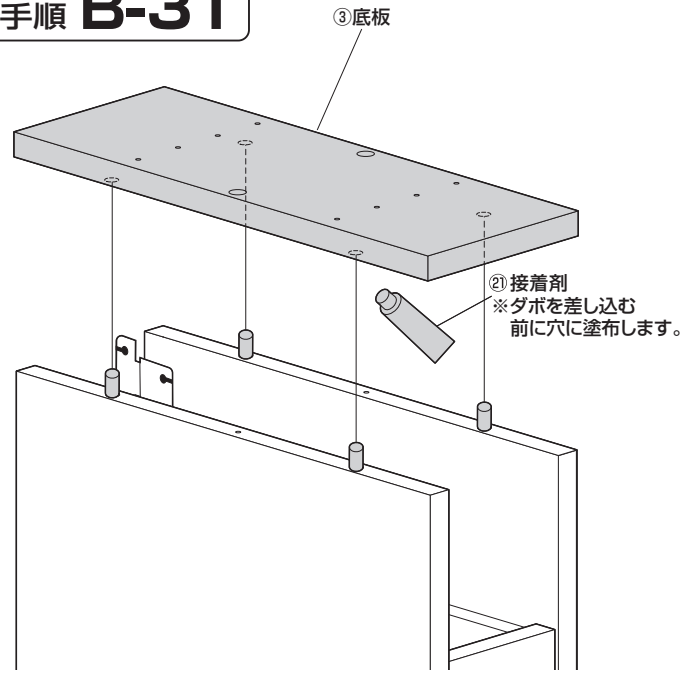

手順 B-32

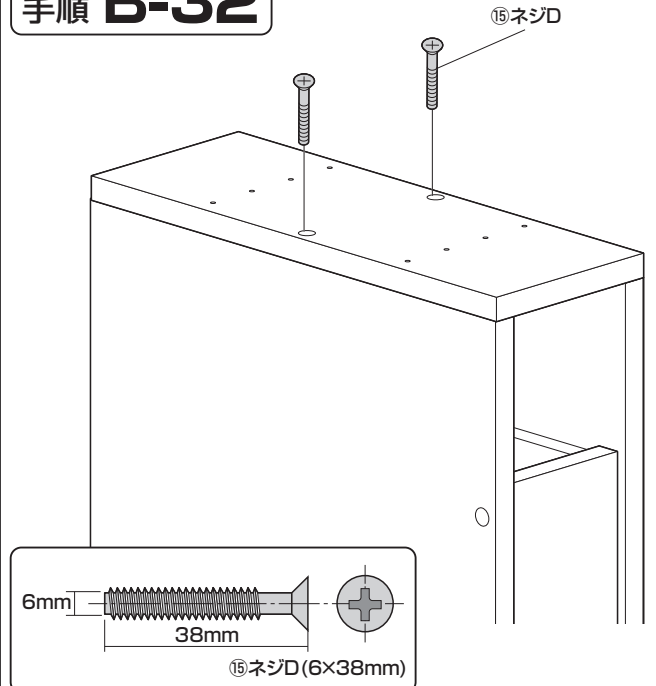

手順 B-33

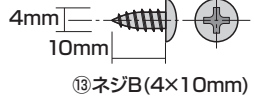
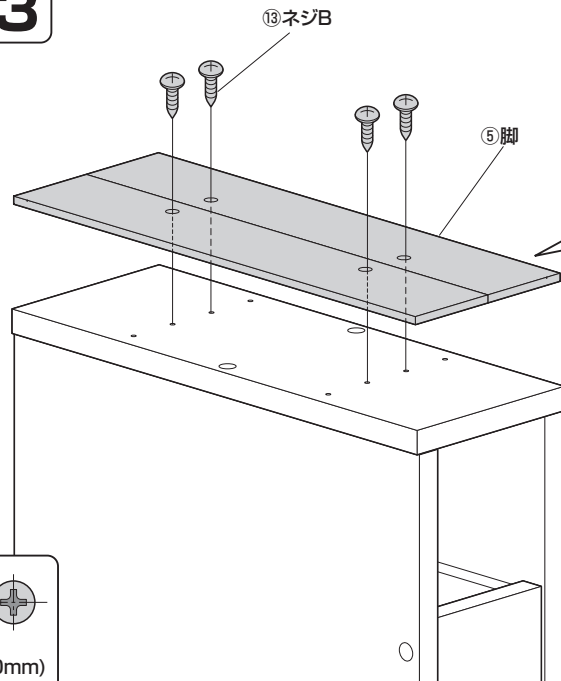

※任意の位置で取付けます。

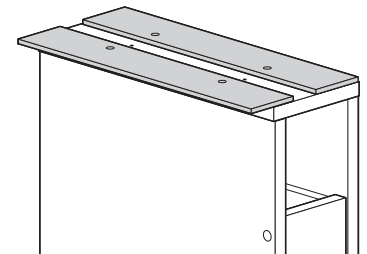
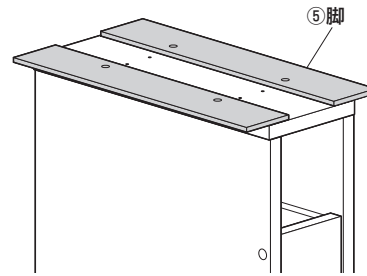

手順 B-34

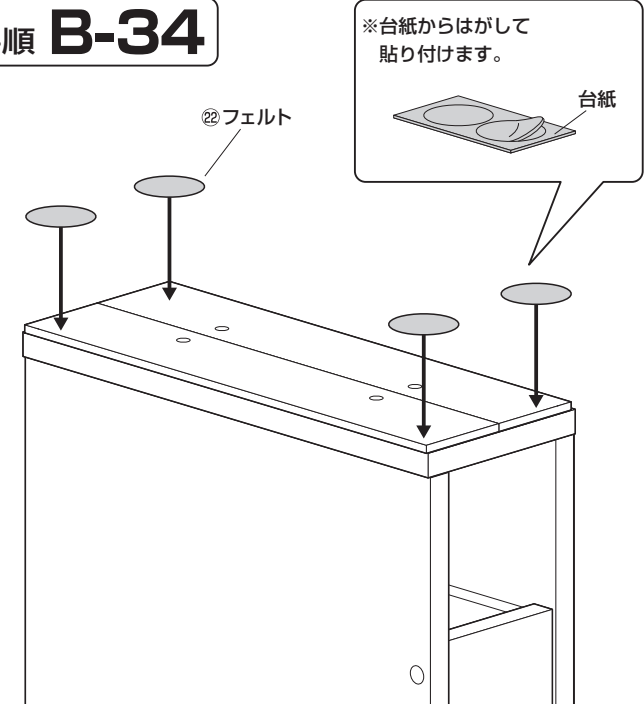

手順 B-35

横にする

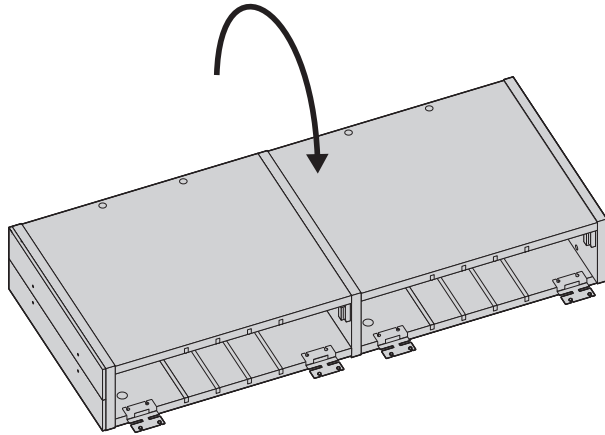

手順 B-36

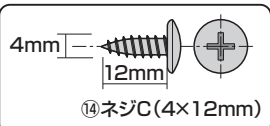
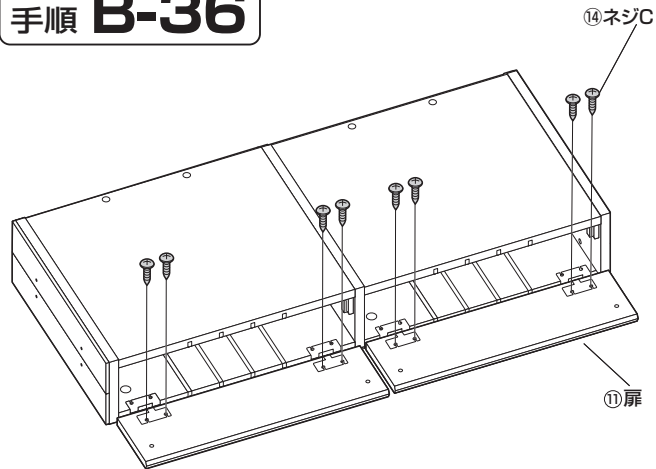

手順 B-37

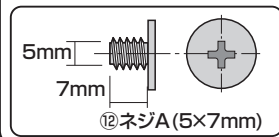
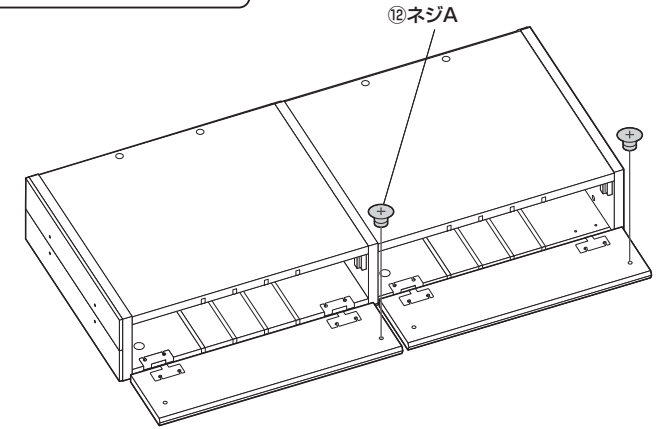

手順 B-38

起こす

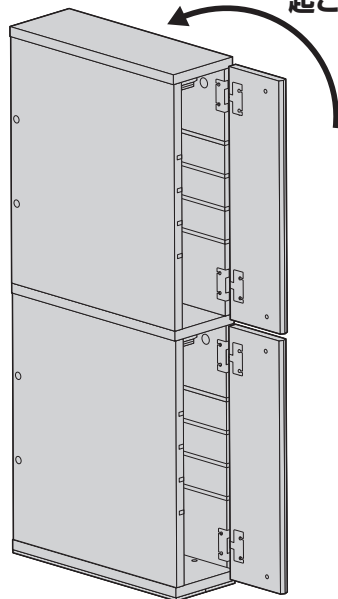

手順 B-39

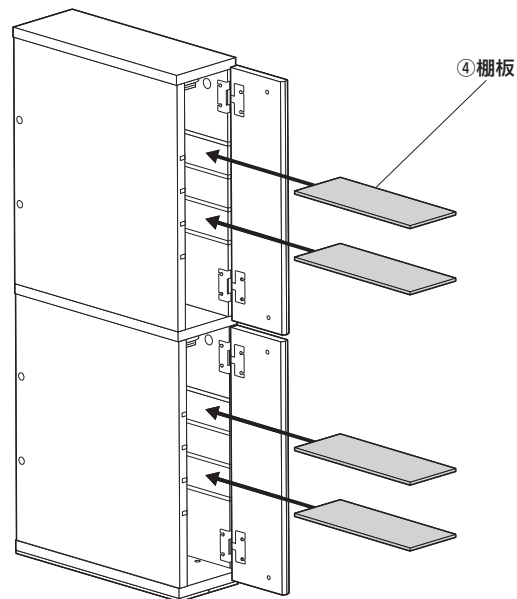

手順 B-40

※台紙からはがして
貼り付けます。

